

911 address shall be a minimum 3" lettering marked on meter enclosure, pole, or durable material attached to pole and should be visible from street. (See sections 1-3, 3, 4)

Also see drawing SS4.6-7, Typical Layout for Mobile Home Park with Multiple Meter Installations.

**Call 48 Hours Before You Dig
1-888-258-0808**

In locations with underground facilities, the Customer shall notify One Call and shall have One Call locate all underground facilities before digging. It shall be the responsibility of the Customer to stay clear of all underground facilities.

Notes:

1. Customer facilities shall comply with Company Standards, the National Electrical Code, and authorities having jurisdiction.
2. Size of conduit to be determined by the Company.
3. This installation applies to two (2) or more meters at one location. Maximum six (6) meters allowed per installation (3 per side).
4. See sections 5.6 and 8.9 for additional information on mobile home parks.
5. If a current transformer (CT) installation is required, see SS11.8-3.
6. Each meter and disconnect shall be plainly marked to designate unit served.
7. The Customer shall install 80lb test non-metallic (manila or grass) pull line or bull tape in the conduit.
8. All material shall be suitable for outdoor use.
9. Equipment to be installed at a location designated by the Company.

ENTERGY SERVICES, INC.			
Multiple Meter Installation For Mobile Home 120/240 Volt Underground Service			
APPROVED BY:	JRH	DATE:	10/24/06
CHECKED BY:	JED	SCALE:	NONE
DRAWN BY:	dtaylo5		
		No. SS4.7-2	
NO.	DATE:	REVISION	BY: APPR:
		PLOT 1=1 SH. 1 OF 1	

911 address shall be a minimum 3" lettering marked on meter enclosure, pole, or durable material attached to pole and should be visible from street. (See sections 1-3, 3, 4)

Typical Overhead Layout for Mobile Home Park

For details on overhead layout for mobile home parks, see drawing SS4.7-1

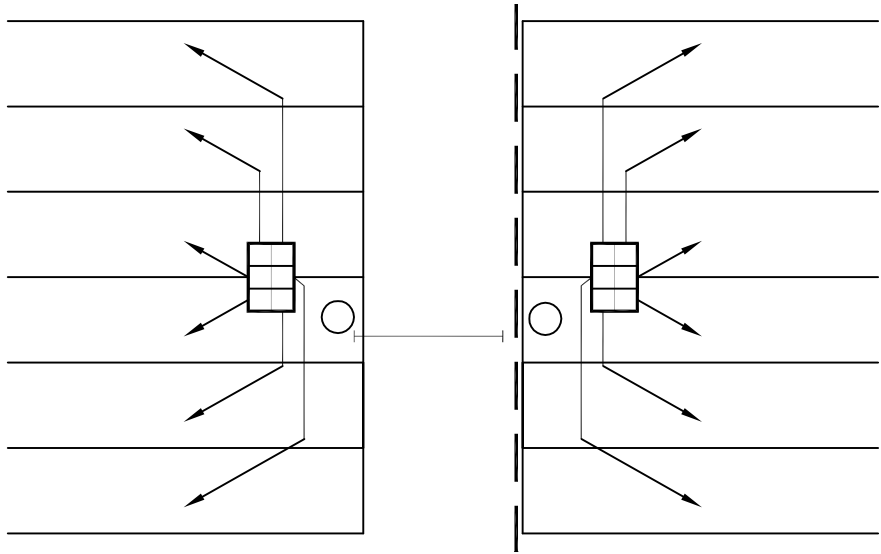

Typical Underground Layout for Mobile Home Park

For details on underground layout for mobile home parks, see drawing SS4.7-2

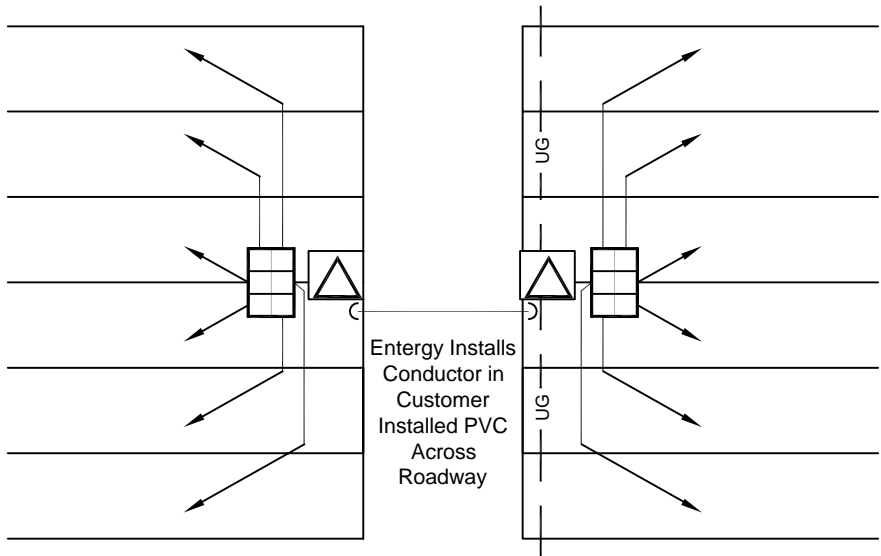

Legend

- Utility Pole
- Entergy Padmount Transformer or Pedestal
- Multiple meter installation by Developer
- Trailer wiring from meter by developer
- Underground Primary Cable
- Overhead Primary Cable

911 address shall be a minimum 3" lettering marked on meter enclosure, pole, or durable material attached to pole and should be visible from street. (See sections 1-3, 3, 4)

**Call 48 Hours Before You Dig
1-888-258-0808**

In locations with underground facilities, the Customer shall notify One Call and shall have One Call locate all underground facilities before digging. It shall be the responsibility of the Customer to stay clear of all underground facilities.

ENTERGY SERVICES, INC.

**Typical Layout for
Mobile Home Park with
Multiple Meter Installations**

APPROVED BY: JRH	DATE: 11/9/06
CHECKED BY: JED	SCALE: NONE
DRAWN BY: dtaylo5	

No. SS4.7-3

Plot 1=1 SH. 1 OF 1

NO.	DATE:	REVISION	BY:	APPR:



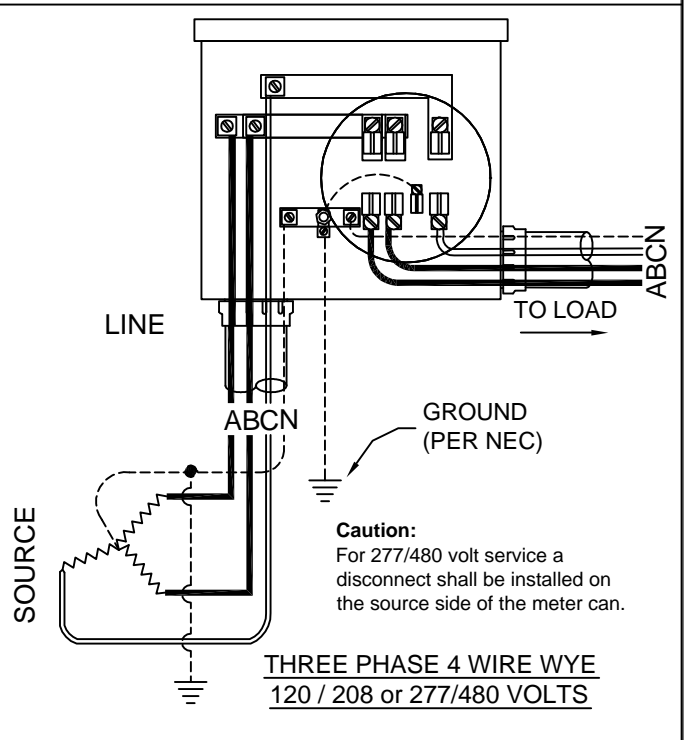
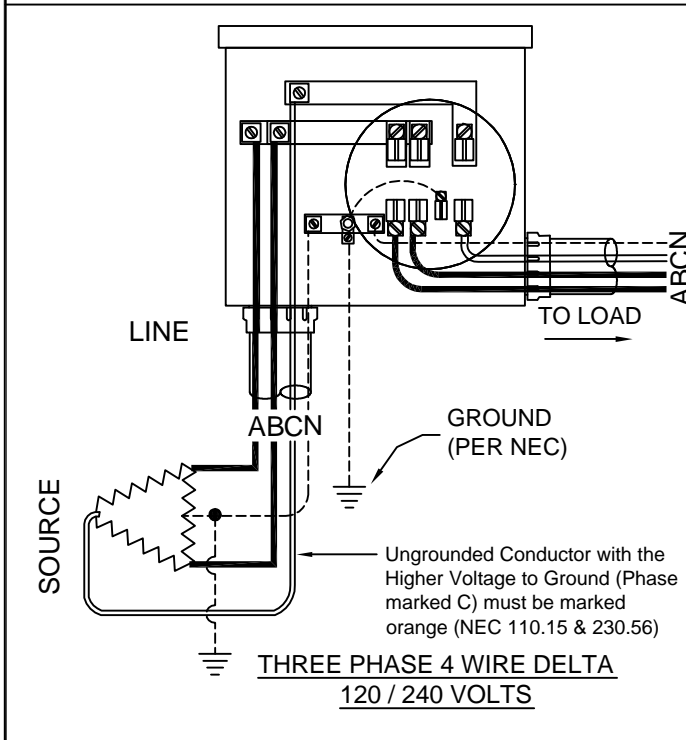
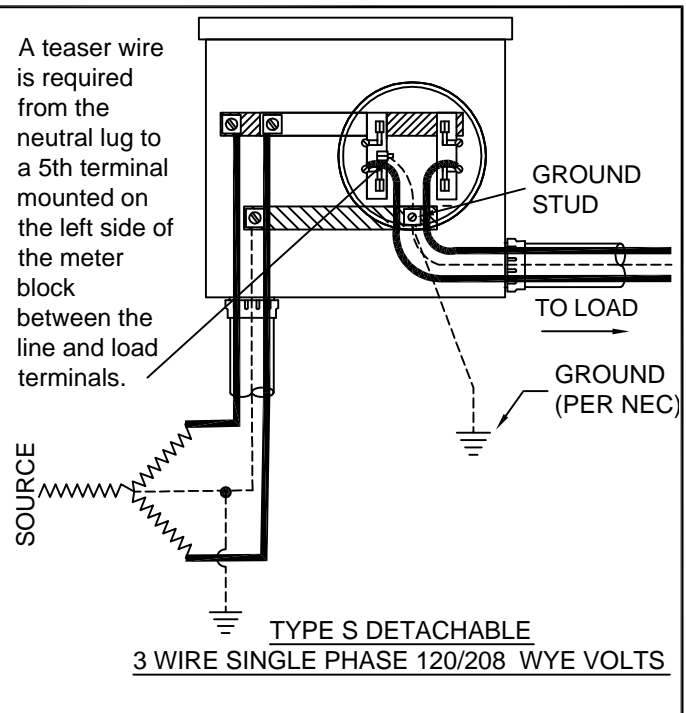
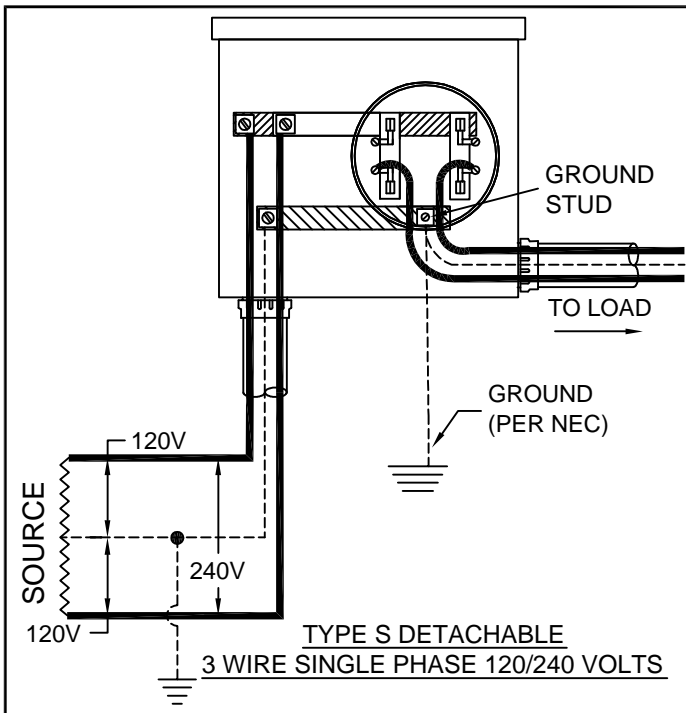

Notes:

1. All diagrams on this drawing show connections when the switch is installed on the right side (see Right Side below) of the meter socket. If the switch is installed on the left side of the meter socket you will need to mirror this diagram (see Left Side below).
2. All sockets, except residential single phase less than 320 Amps, shall have a manual mechanical gang operated bypass switch.
3. Load and supply wires shall not cross in the meter socket (11.1.2.7)

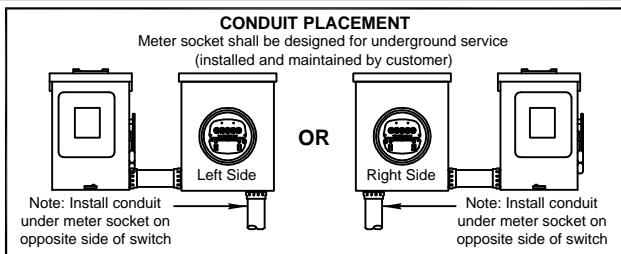

ENTERGY SERVICES, INC.			
WIRING DIAGRAM CONNECTIONS FOR UNDERGROUND SELF CONTAINED METERS			
APPROVED BY:	JRH	DATE:	APRIL 2005
CHECKED BY:	JED	SCALE:	NONE
DRAWN BY:	DAT		

1	3/08	UPDATED: CUSTOMER INSTALLATION STANDARDS TEAM	DAT
NO.	DATE:	REVISION	BY: APPR:

	No. SS11.8-2	
	PLOT 1=1	SH. 2 OF 2